

Santiago 3-in-1 i-Size Luxe Travel System

Instruction manual

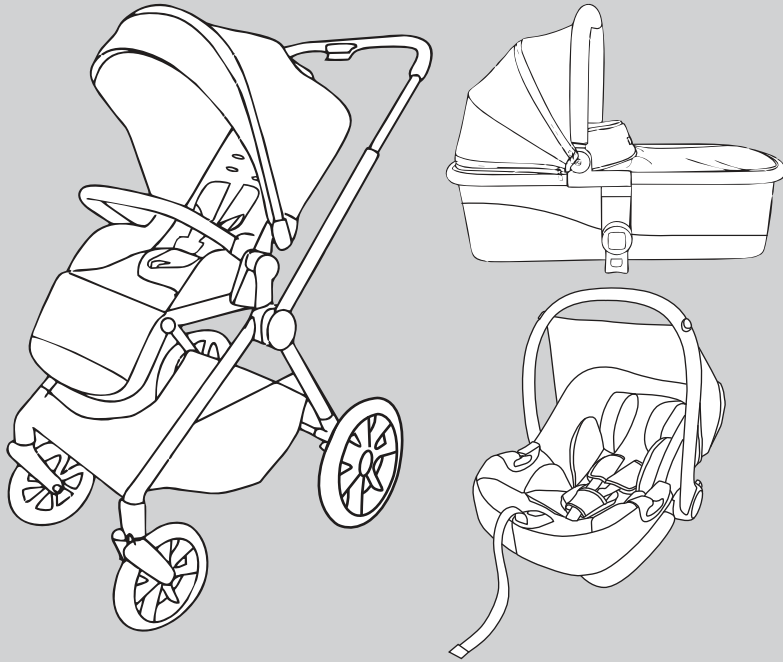

**IMPORTANT! READ CAREFULLY
AND KEEP FOR FUTURE REFERENCE.**

Warning: A child's safety is your responsibility.

This product is tested and approved to
BS EN 1888-2:2018+A1:2022 & EN 1466:2023

1. Welcome

Thank you for purchasing the Puggle Santiago 3-in-1 i-Size Luxe Travel System.

Please read the instructions and warnings carefully before use to ensure safe and satisfactory operation of your Puggle Santiago 3-in-1 i-Size Luxe Travel System.

If you have a query with this product or require replacement parts, please contact Online4baby online at [online4baby.com/contact-us](https://www.online4baby.com/contact-us).

2. Safety instructions

IMPORTANT! PLEASE READ THE FOLLOWING INSTRUCTIONS CAREFULLY BEFORE INSTALLING THE PRODUCT.

- **WARNING!** Keep for future reference. The child may be hurt if you do not follow these instructions.
- **WARNING!** A child's safety is your responsibility.
- **WARNING!** This product is suitable for one child from birth (max. weight 22kg or 4 years whichever comes first).
- **WARNING!** Suitable from birth in pram mode up to a maximum weight of 9kg or until the child can sit up unaided, roll over or push itself up on its hands and knees.
- **WARNING!** Use the most reclined position for new born baby.
- **WARNING!** Follow suitability recommendations given in the separate infant car seat instruction manual.
- **WARNING!** Never leave the child unattended.
- **WARNING!** Ensure all locking devices are engaged before use.
- Always apply the parking brake when the product is stationary.
- Ensure the parking brake is engaged during the loading and unloading of the child.
- Take extra care in windy conditions.
- Be careful when going up or down kerbs.
- **WARNING!** To avoid injury ensure that your child is kept away when unfolding and folding this product.
- **WARNING!** Do not let your child play with this product.
- **WARNING!** Always use the restraint system.
- **WARNING!** Always use the crotch strap in combination with the waist belt section of the harness.
- **WARNING!** Check that the pram body or seat unit or car seat attachment devices are correctly engaged before use.
- **WARNING!** This product is not suitable for running or skating.
- **WARNING!** Do not let other children play or hang on the product.
- **WARNING!** Do not use this product if any part is broken, torn or missing.
- **WARNING!** Do not add an additional mattress to the seat unit when in pram mode.
- **WARNING!** Do not place the product near an open fire or other source of strong heat.

2. Safety instructions

- Adult assembly is required.
- When in use, the head of the child in the product should never be lower than the body of the child.
- Any load attached to the handle and/or on the back of the backrest and/or on the sides of the vehicle will affect the stability of the vehicle.
- Bags and other items should not be hung from the handles as this can affect the stability of the product.
- Do not use parts or accessories which are not approved by the manufacturer.
- Do not allow your child to climb unassisted into the product.
- Remove your child and fold the product when going up or down escalators.
- If this product is used by someone unfamiliar with it e.g. grandparents, always show them how it works.
- A basket is provided for the carriage of 2kg of items evenly distributed.
- Infant car seats should not be used in place of a cot or cot bed. Should your child need to sleep then it should be placed in a suitable pram body, cot or cot bed.
- Overloading, incorrect folding and the use of non-approved accessories is unsafe and may damage or break this product.
- Never leave the raincover, hood or apron on indoors, in a hot atmosphere or near a heat source as your child may overheat.
- To prevent damage, remove the raincover before folding the pushchair.
- Do not place anything on top of the raincover.
- Only use the pram body or seat unit or car seat on the Santiago chassis.
- This product conforms to BS EN 1888-2:2018+A1:2022 & EN 1466:2023

3. Parts List

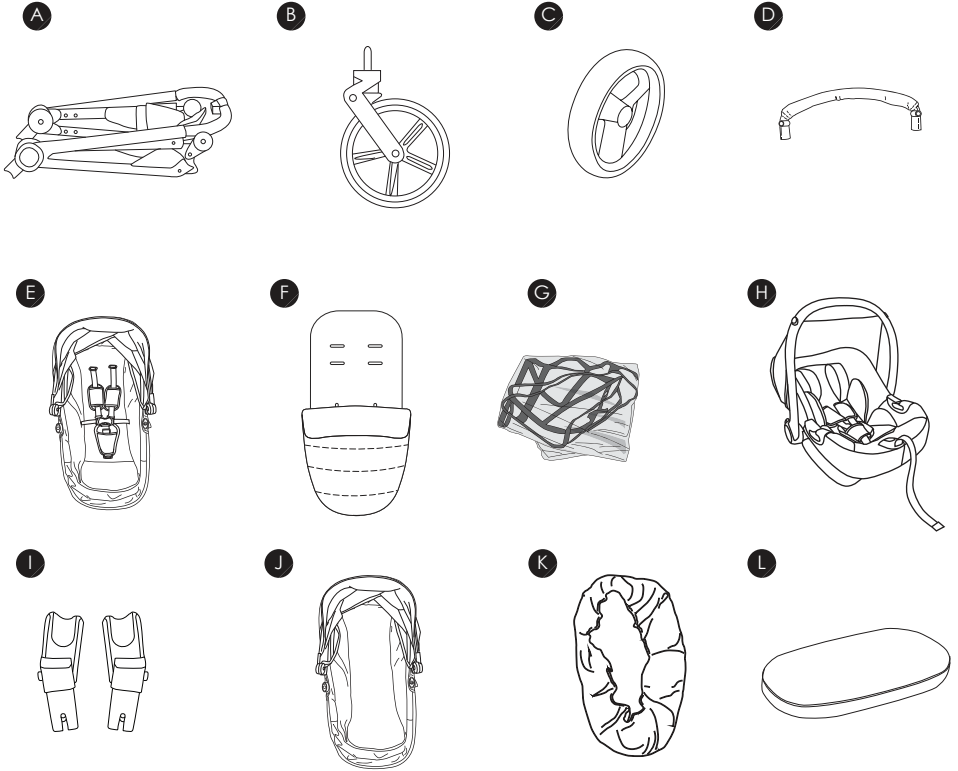

Contained in your carton are:

Nº	Part	Qty
A	Chassis	1
B	Front wheels	2
C	Rear wheels	2
D	Bumper bar	1
E	Seat unit	1
F	Apron with liner	1
G	Raincover	1
H	i-Size infant carrier	1
I	i-Size infant carrier adaptors (set)	1
J	Carrycot	1
K	Carrycot lining	1
L	Carrycot mattress	1
M	Carrycot apron	1

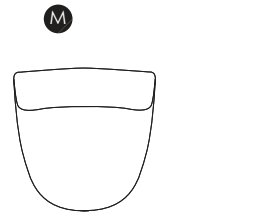

4. Assembly

4.1. CHASSIS ASSEMBLY

Lift the handle to open the chassis (A).

When the chassis is completely open, you will hear a “click” indicating it is locked into place.

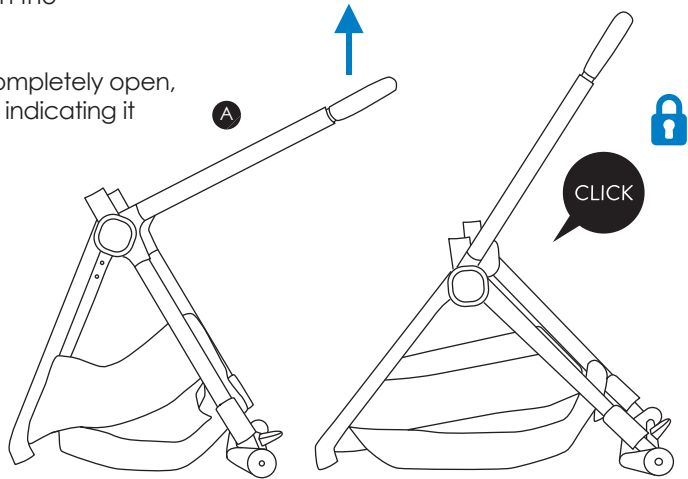

4.2. REAR WHEEL ASSEMBLY

Push each rear wheel (C) into the sides of the rear wheel axle until you hear a “click”.

Give them a tug to ensure they are attached securely.

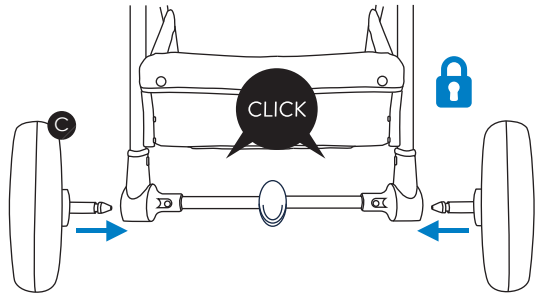

To remove the rear wheels, simply pull out the metal latch located underneath the rear wheel axle and pull the wheel out.

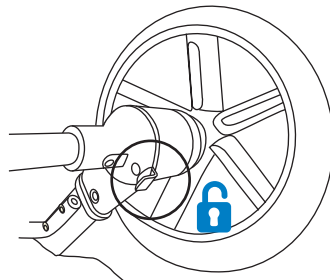

4. Assembly

4.3. FRONT WHEEL ASSEMBLY

Insert each of the front wheel (B) pins into the center of the socket until you hear a "click". Give each wheel a firm tug to ensure they're securely attached.

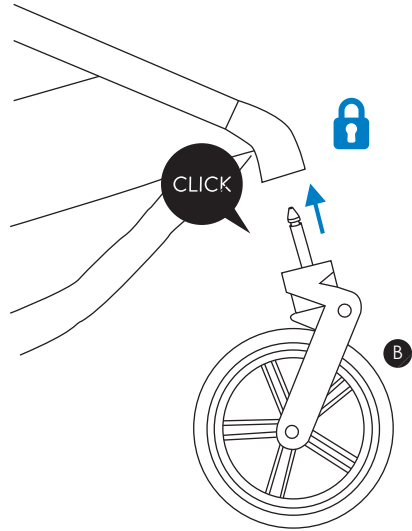

To remove the front wheels, simply press the button at the back of the wheel socket and pull down.

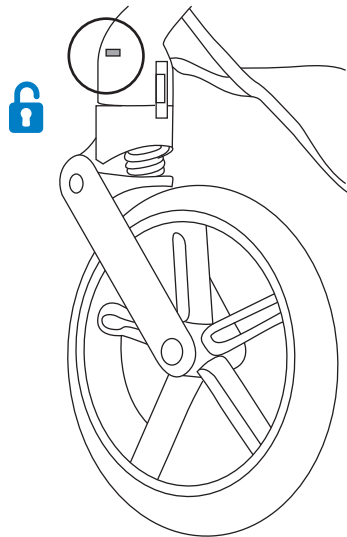

4. Assembly

4.4. CARRYCOT BASE ASSEMBLY

Set up the carrycot (J). Pull the black metal rods into place as shown. This will give your carrycot its structure



WARNING!

Ensure metal rods are fully engaged before continuing. Failure to do so could cause collapse and fatality.

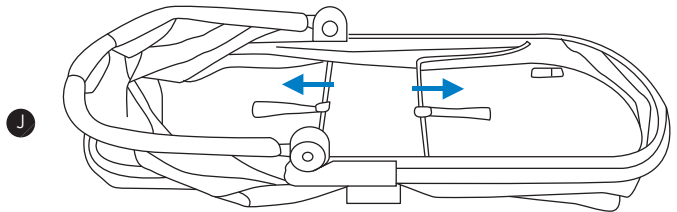

Zip the carrycot lining (K) onto the frame and insert the carrycot mattress (L).

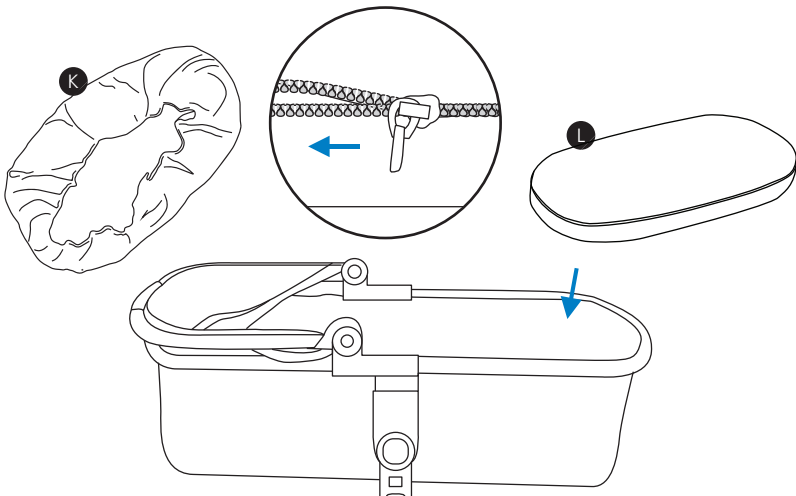

WARNING!

Do not add an additional mattress to the carrycot.

4. Assembly

4.5. CARRYCOT CANOPY AND APRON ASSEMBLY

The canopy can be opened or closed. Press the buttons either side of the canopy to adjust the position up and down.

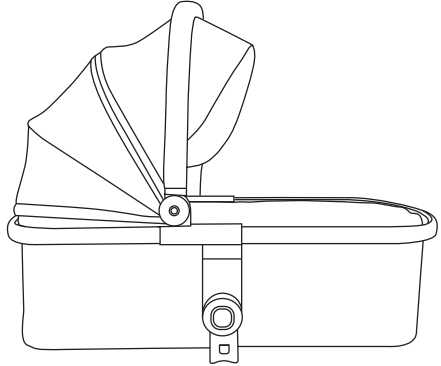
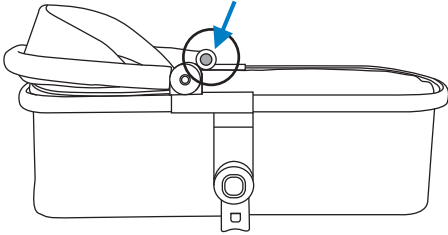

The canopy has an extension panel. Open the zip and pull forward on the front of the canopy to extend it out.

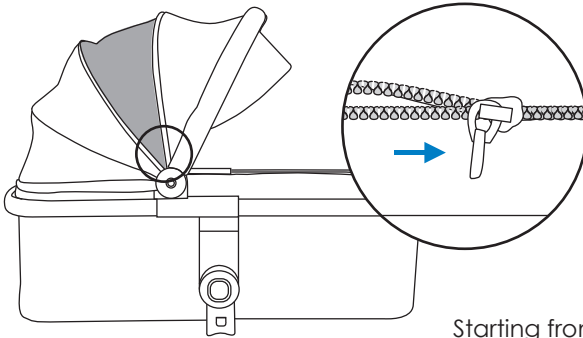

Starting from the right, zip the apron (M) onto the carrycot (at the opposite end to the canopy).

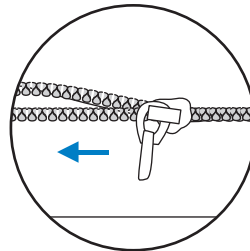
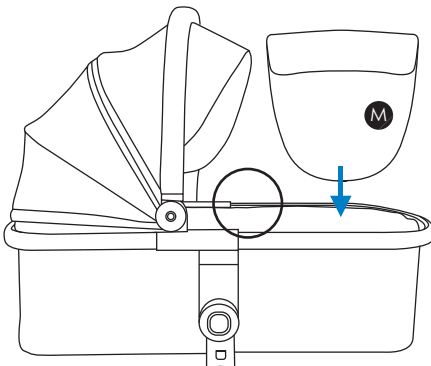

5. Pram Mode

5.1. ATTACH CARRYCOT TO CHASSIS

Line up the connectors with the chassis housing and press downwards. Listen for a 'click' to signal correct assembly.

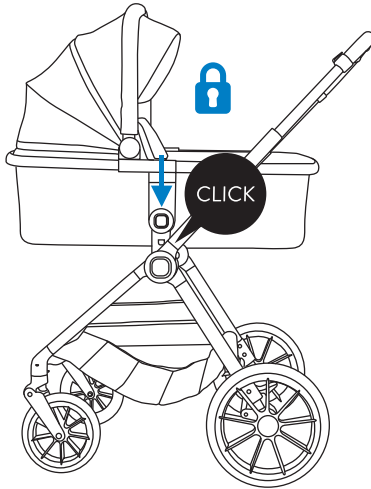

Press the buttons both sides of the connectors to remove the carrycot from the chassis.

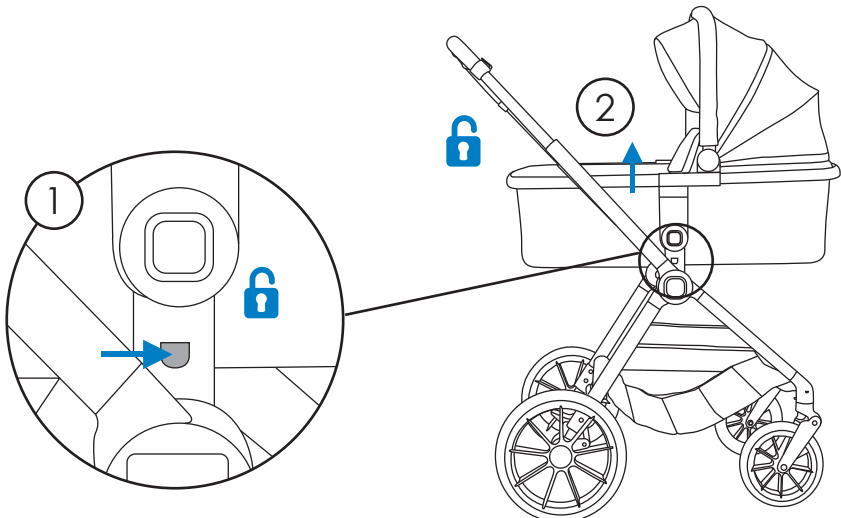

5. Pram Mode

5.2. USING PRAM MODE

Suitable from birth in pram mode up to a maximum weight of 9kg or until the child can sit up unaided, roll over or push itself up on its hands and knees.



WARNING!

Never use in pram mode with carrycot forward facing.

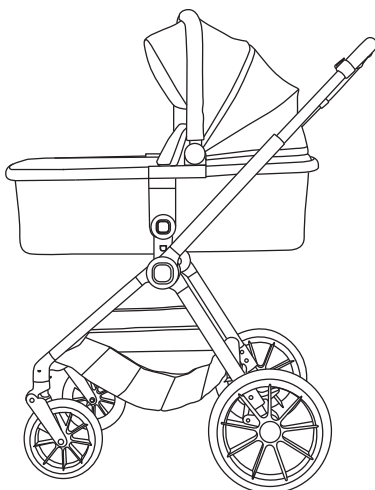
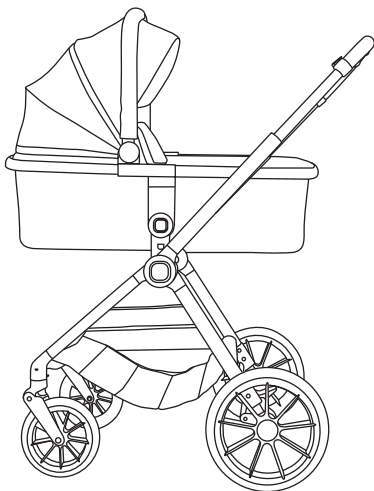

6. Pushchair Mode

6.1. OPENING THE SEAT UNIT

Pull up on the top portion of the seat unit (E) to open it out, then pull up the bumper bar connectors. You will hear a "click" indicating the seat unit is locked into place.

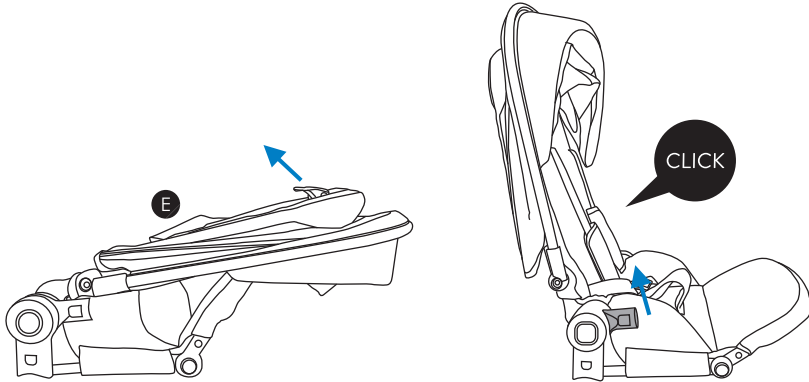

6.2. SEAT UNIT BUMPER BAR

Insert the bumper bar (D) into the slots ensuring that the release buttons are on the outside and you hear a 'click'. Give the bumper bar a tug to ensure it's securely in place.



WARNING!

The seat unit is not designed to be carried by the bumper bar when containing your child. Remove your child from the seat unit before lifting.

To remove the bumper bar, simply press the release buttons on either or both sides and lift up.

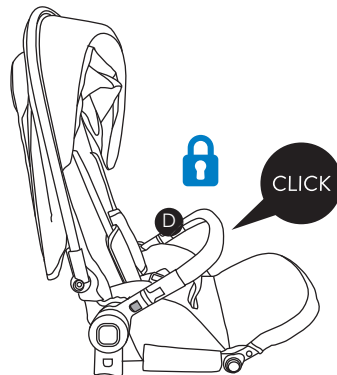

6. Pushchair Mode

6.3. ATTACH SEAT UNIT TO CHASSIS

Attach the seat unit to the chassis. Line up the seat connectors with the chassis housing and press downwards. Listen for a 'click' to signal correct assembly.

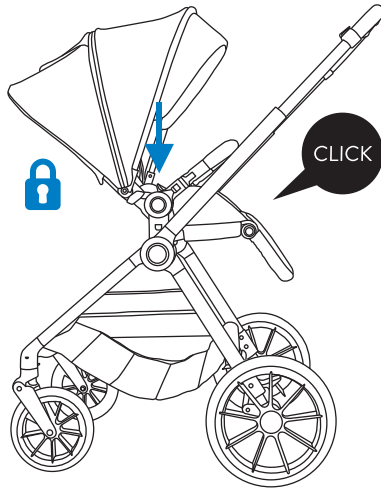

Press the buttons both sides of the connectors to remove the seat unit from the chassis.

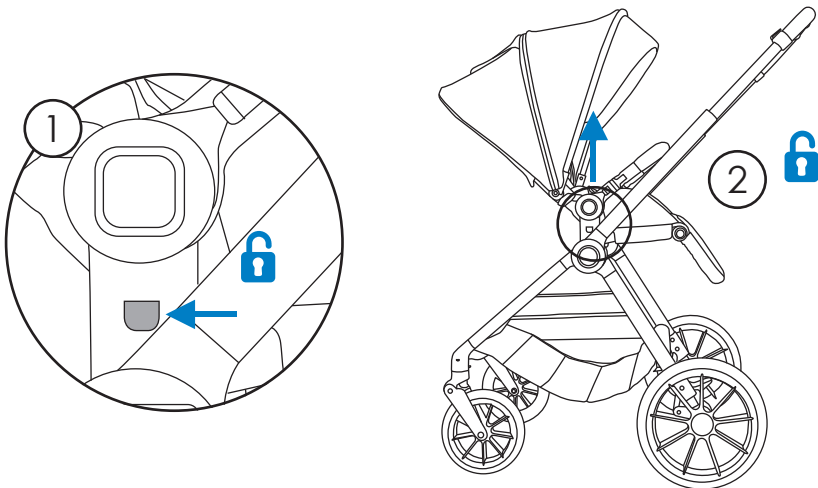

6. Pushchair Mode

6.4. BACKREST ADJUSTMENT

Lift the lever on the top rear of the seat unit to adjust the seat recline. Ensure you hear a "click" as the seat engages at your desired position.

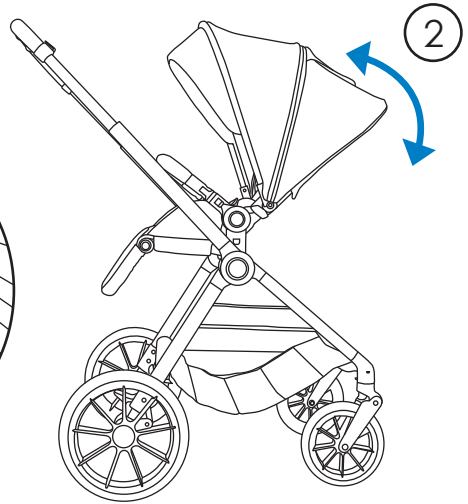
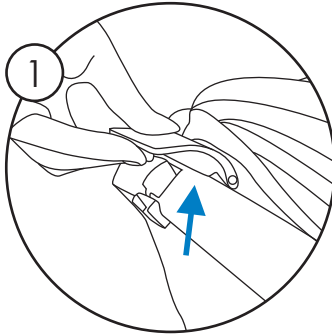

6. Pushchair Mode

6.5. REVERSIBLE SEAT UNIT

The seat unit is reversible in pushchair mode. It can be forward or parent facing.

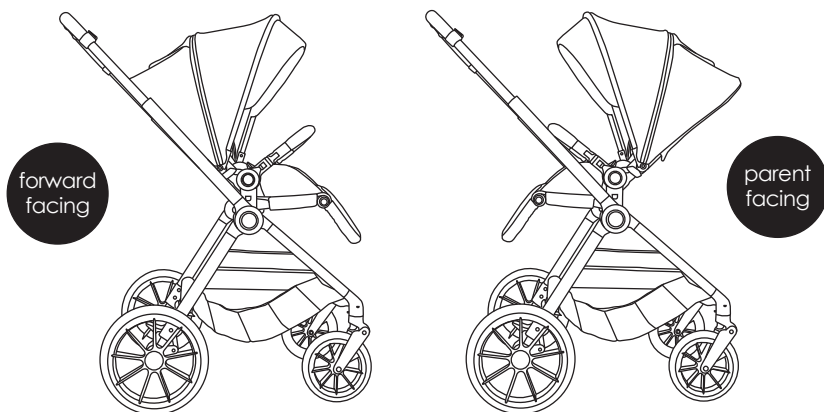

Press the buttons both sides of the seat connectors to remove the seat unit from the chassis.

To re-attach the seat unit to the chassis, line up the seat connectors with the chassis housing and press downwards. Listen for a "click" to signal correct assembly.

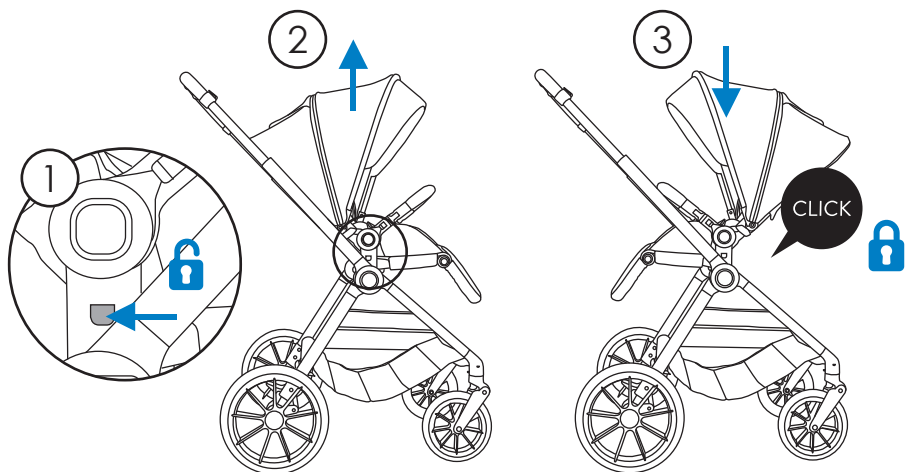

7. In Use

7.1. HARNESS OPERATION

Slide the shoulder strap buckle onto the housing of the waist strap buckle.
Repeat for the opposite side.

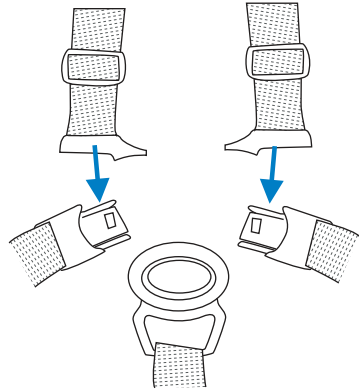

Insert the completed buckle into the buckle housing until it engages securely in place. Listen for the "click".
Repeat for the opposite side.

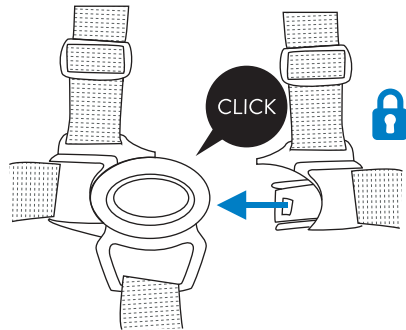

Press the centre button to release child from harness.

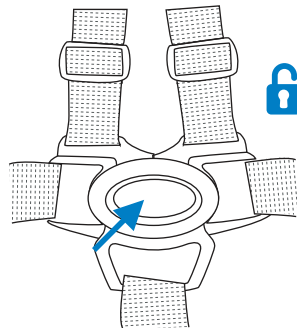

7. In Use

7.2. HARNESS ADJUSTMENT

To adjust the shoulder straps, move the slides as shown.



WARNING!

Always adjust the harness to fit your child correctly for their comfort and safety. A loose fitting harness can be very dangerous.

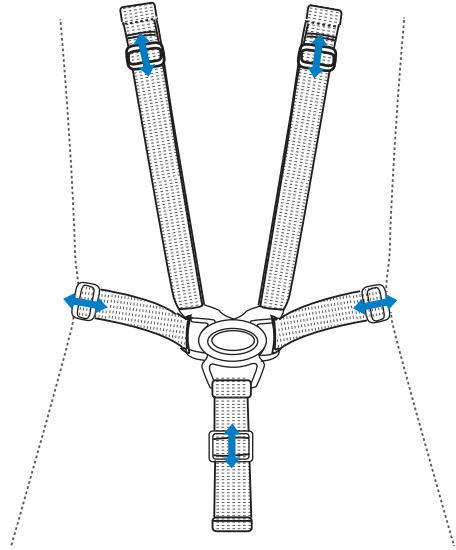

There are 2 shoulder height positions. Undo the harness and remove the shoulder pads. Thread the end of the harness through the slots at the front of the backrest to adjust the height position.



WARNING!

Always adjust the shoulder strap height according to baby height.

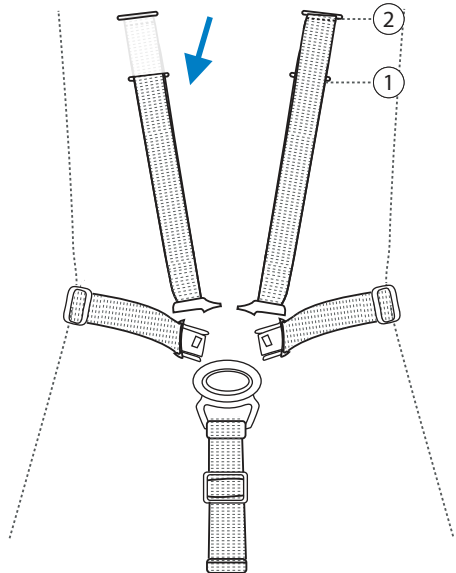

7. In Use

7.3. THE CANOPY

The canopy can be opened or closed by pulling forward or backward on the canopy rim.

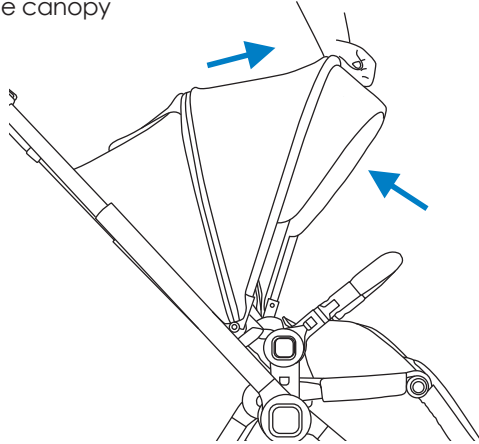

The canopy features an extension panel and a mesh window for ventilation and to keep an eye on baby in forward facing position.

Lift the flap to reveal the window and open the zip to extend the canopy.

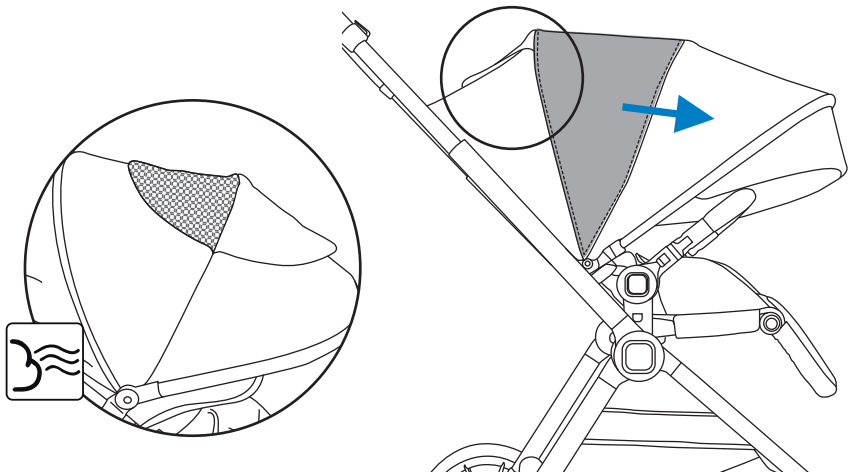

7. In Use

7.4. HANDLE ADJUSTMENT

Push and hold the handle height adjustment button.
At the same time adjust the handle up or down.

Release button at your
desired position. Listen for the
"click" to ensure the handle
is secure.

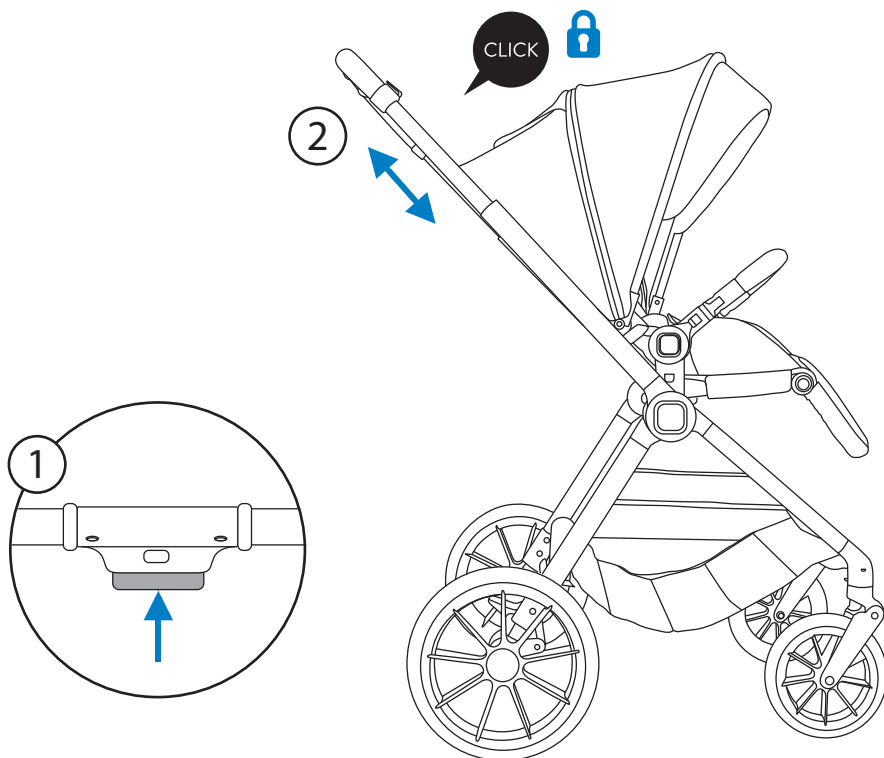

7. In Use

7.5. SWIVEL WHEELS

When travelling along straight surfaces or uneven terrain, the front wheels may spin.

To lock the front swivel wheels into place, push the swivel lock down.

To go back to 360° swivel mode, push the lock up.

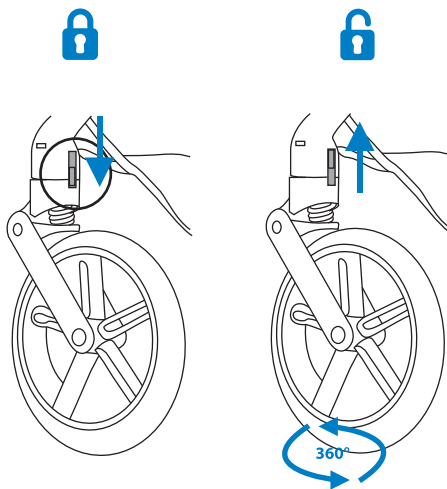

7.6. BRAKES

Press down on the brake pedal to engage the brake.

Listen for the "click" signalling that the brake is locked.

Push the brake pedal upwards to disengage the brake.



WARNING!

Always apply the parking brake when the pram is not moving.



WARNING!

Always apply the brake when you are placing and removing the child.

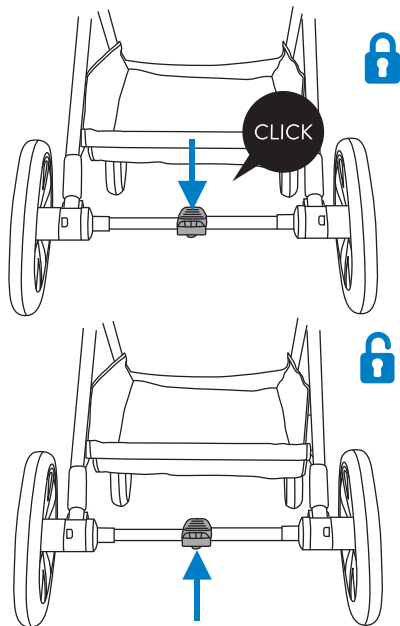

7. In Use

7.7. FOOTREST ADJUSTMENT

Press both footrest buttons simultaneously and adjust the footrest to the desired position. Listen for the "click" signalling that the footrest is locked into position.

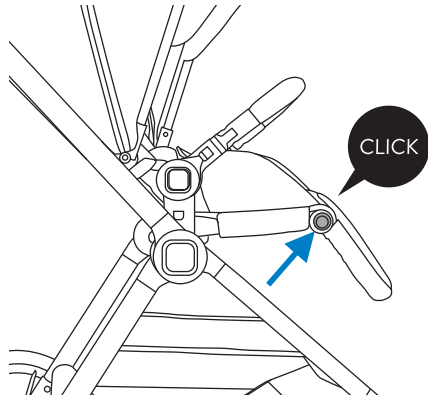

7.8. APRON WITH LINER

There is an apron with liner (F) included for the seat unit. Undo the harness and remove the chest pads. Thread the harness through the slots in the liner and reattach the chest pads. Thread the crotch pad and crotch harness through the allocated slot in the liner. Fold apron flap over bumper bar.

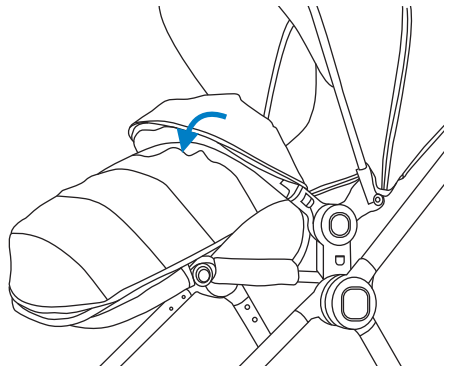
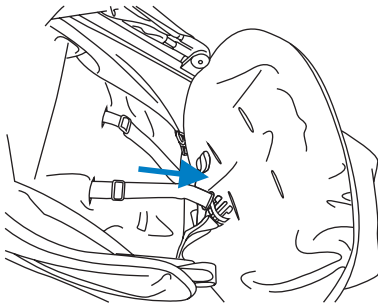
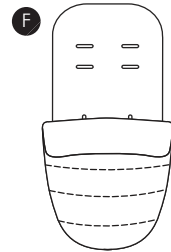

7. In Use

7.9. RAINCOVER

Locate the raincover (G). Pull the raincover down over the stroller starting at the top of the canopy and pulling down towards the footrest.

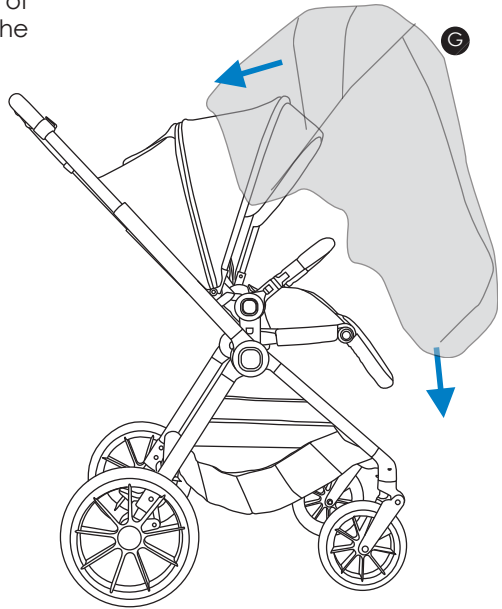

NOTE. The raincover will fit the seat unit in both pram and pushchair mode.

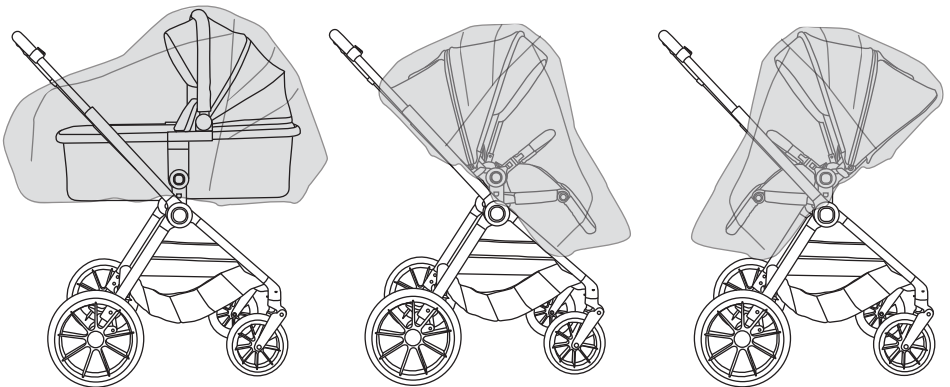

8. Travel System

8.1.1. ATTACHING i-SIZE INFANT CARRIER TO THE CHASSIS

An i-size infant carrier (H) and set of adaptors (I) are included to complete the travel system.

Remove the seat unit/carrycot from the chassis to fit the adaptors.
Line up the adaptors with the chassis housing and press downwards.
Listen for a “click” to signal correct assembly.

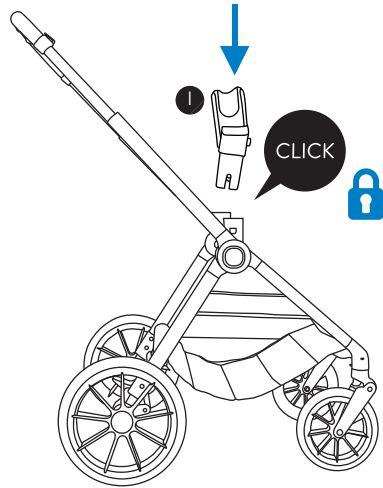

8.1.2. ATTACHING i-SIZE INFANT CARRIER TO THE CHASSIS

Place the infant carrier (H) onto the adaptors.
Push down to “click” into place.
Lift by handle to ensure car seat is secure.
Alternatively, attach the adaptors to the infant carrier first and then attach the infant carrier to the chassis.

 **WARNING!**
Never attach the car seat forward facing.

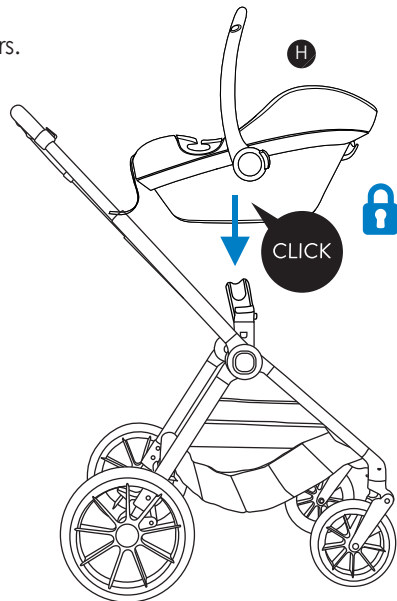

8. Travel System

8.2.1. DETACHING i-SIZE INFANT CARRIER FROM THE CHASSIS

Press the button located on the side of the car seat and pull upwards to remove.

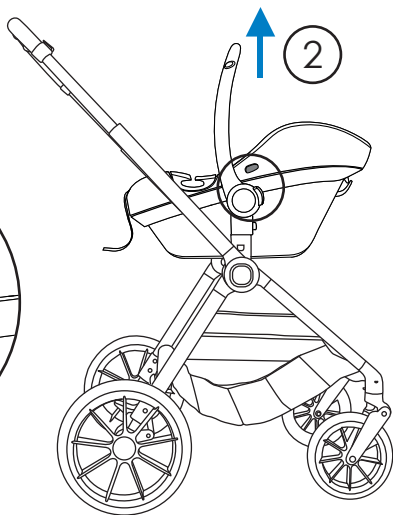
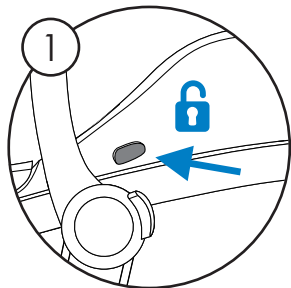

8.2.2. DETACHING i-SIZE INFANT CARRIER FROM THE CHASSIS

Press button on both sides of the adaptors to remove the adaptors from the chassis.

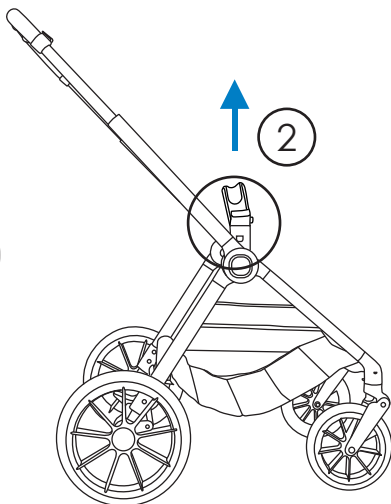
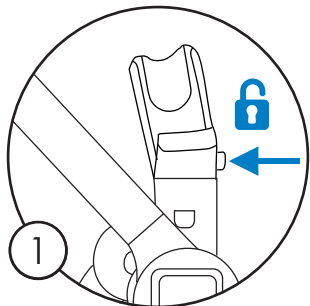

9. Folding

9.1. FOLDING SEAT UNIT

NEVER fold chassis with the infant carrier or carrycot attached.

ALWAYS fold the canopy before folding and apply the brakes.

Lift the lever on the top rear of the seat unit and push the seat unit forward to a close.

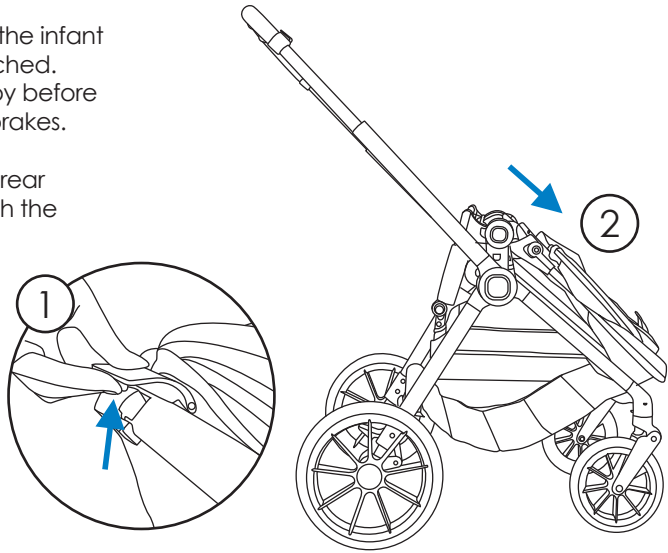

9.2.1. FOLDING CHASSIS

Adjust the handle to the lowest position.

Located on the chassis, hold in the second lock and simultaneously pull up on both folding lock buttons. Push the chassis handle down to a close.

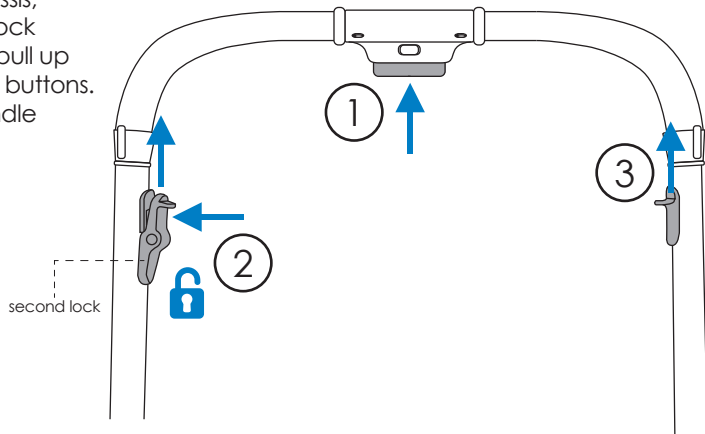

9. Folding

9.2.2. FOLDING CHASSIS

Pull up on the handle to complete closing the stroller.



WARNING!

To avoid injury ensure that your child is kept away when unfolding and folding this product.

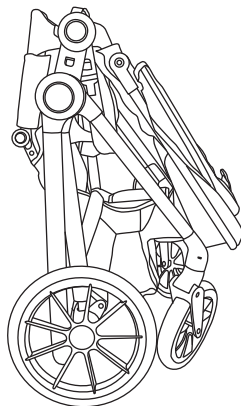
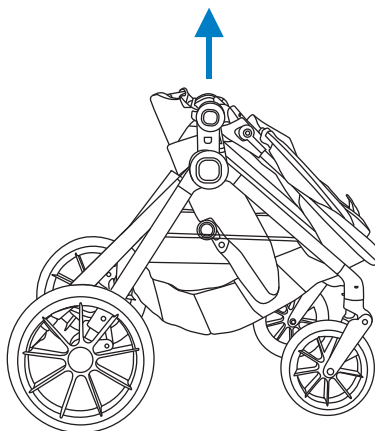

10. Care and Maintenance

10.1. CLEANING

- Spot or sponge clean fabrics with mild detergent. Use mild soap or upholstery shampoo. NEVER use bleach. Dry in shade thoroughly before reuse and avoid direct heat and sunlight. Do not iron. Do not dry clean.
- Wipe clean plastics and metals with a damp cloth.
- Never clean any part of the product with abrasive, ammonia based, bleach based or spirit type cleaners.
- Ensure the product is fully dry before use or storage.
- Always ensure the product is stored in a dry place to prevent mold or mildew developing.

10.2. MAINTENANCE

- The product requires regular maintenance to ensure correct and safe performance.
- Regularly inspect the wheels, locks, brakes, harness, catches, seat adjusters, joints and fixings to ensure they are clean, operating correctly and in full working order.
- Replace tyres if they are excessively worn.
- Do not use this product if any part is broken, torn or missing and use only spares provided by the manufacturer.
- If parts become stiff or difficult to operate, ensure dirt is not the cause, then try a light application of a silicon lubricant, ensuring it penetrates between the components. Regular lubrication of moving parts will extend the life of your product and make opening and folding easier.
- After exposure to damp conditions, dry off with a soft cloth and leave fully open in a warm environment. Storing damp will encourage mildew to form.
- Store in a dry place.
- Do not leave in sunlight for prolonged periods as some fabrics may fade.



If you have any questions or concerns regarding this product,
do not hesitate to contact our expert team online
via online4baby.com/contact-us

Feeling social?  
online4baby.com

Imported by Online4baby Ltd,
Meadowbank, Tweedale Way, Oldham, OL9 8EH