

Slimline Twin Duo Stroller

Instruction manual

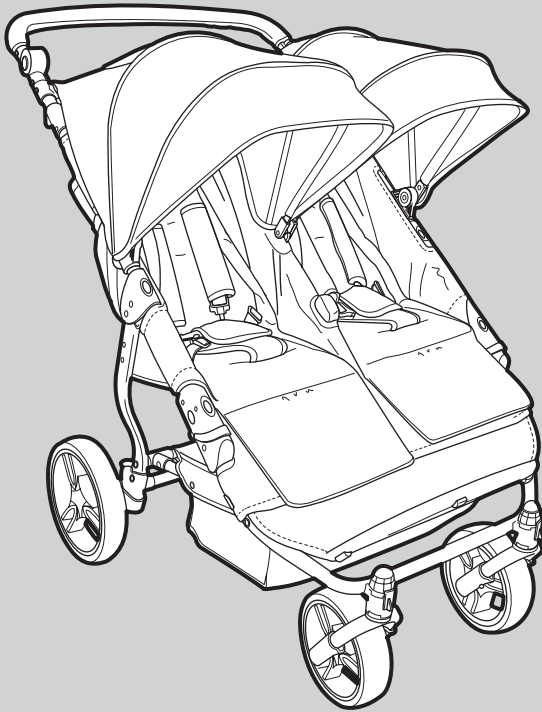

IMPORTANT: READ CAREFULLY AND KEEP FOR FUTURE REFERENCE.

Suitable for children from: BIRTH up to 15kg

This product is tested to: BS EN 1888-1:2018+A1:2022

Safety instructions

WARNING

Never leave your child unattended.

Ensure that all the locking devices are engaged before use.

To avoid injury ensure that your child is kept away when unfolding and folding this product.

Do not let your child play with this product.

Check that the pram body, pushchair body or seat unit attachment devices are correctly engaged before use.

This pushchair is not suitable for running or skating.

Always use the restraint system.

Always use the crotch strap in combination with the waist belt.

This product is suitable for children from birth to 15kg.

- *The compatible carrycot is suitable from birth to 9kg (sold separately).*
- *The compatible car seat is suitable from birth to 13kg (sold separately).*

NEVER run or rush across a road with your pushchair. NEVER use your pushchair in a way for which it is not designed.

Always apply the brakes when the pushchair is stationary, and when placing and removing children. When the parking brake is used, always test it is properly applied by pushing on the handle of the pushchair.

Parcels, accessories and other items (e.g. hand bags, shopping bags, etc) that are placed on the handles, back of the backrest or sides of the pushchair will affect the stability of the pushchair and can cause failure of one or more components of the pushchair.

Do not lift and carry the pushchair with a child in it.

Ensure that children are clear of moving parts before making adjustments.

This product is designed to carry only one child per seat at a time.

Taking children up or down stairs, escalators, steps, steep slopes and muddy/rough terrain could be dangerous and should not be attempted. Remove your child from the pushchair for easy carrying to negotiate such hazards, or simply avoid them.

Do not use replacement parts or accessories other than those approved by the manufacturer as others may render the product unsafe.

Do not load the basket with a weight in excess of 3kg.

If your pushchair is to be used by someone who is unfamiliar with it, e.g. grandparents, then show them how it works before letting them use it.

Never leave raincovers, hoods and aprons on indoors or in hot weather as your child might overheat.

Do not allow your child to climb unassisted into or out of the pushchair.

Always use the most reclined position for new born babies.

When using the compatible carrycot: Do not use or add a mattress other than the one supplied with the carrycot. Do not add another mattress on top of the one provided.

All references to Left and Right are based from the perspective of someone stood in front of the pushchair.

If you have special harness requirements and wish to attach your own harness, then there are 'D' rings provided on the waist harness for the attachment of your alternative harness system. The alternative harness system must conform to BS EN 13210:2020.

Welcome

Thank you for purchasing the Puggle Slimline Twin Duo Stroller. Please read the instructions and warnings carefully before use to ensure safe and satisfactory operation of this product.

Your child's safety is your responsibility. If you have a query with this product or require replacement parts, please contact us at online4baby.com/contact-us.

Lay out the parts on a soft level surface and compare to the part/fixings checklist below. Do not discard any packaging until you are sure that you have all the parts.

WARNING! Assembly by an adult. Keep away from children until fully assembled. Keep children clear during assembly as pack contains small parts which may present a choking hazard.

Care and maintenance

- This product requires regular maintenance: Inspect the locking devices, brakes, harness assembly, catches, seat adjustments, joints and fittings to ensure they are secure and in full working order. Brakes and wheels are subject to wear and should be replaced if necessary by contacting customer service.
- If any part of your pushchair becomes stiff or difficult to operate, ensure that dirt is not the cause. Use spray lubricant (silicone based) between the components. Avoid over-spraying as this may encourage the accumulation of dirt. Regular lubrication of moving parts will extend the life of your pushchair and make opening and folding easier.
- The seat unit, plastic and metal parts must be sponged clean with warm water and mild detergent. Always allow to dry thoroughly before using or storing.
- Do not leave the pushchair in sunlight for prolonged periods as fabrics may fade.
- Never use abrasives, ammonia, bleach or spirit based cleaners.
- Always store your pushchair in a dry place. Allow fabric and raincover to dry thoroughly before folding and storing.
-

WARNING: Parcels, accessories and other items (e.g. hand bags, shopping bags, etc) that are placed on the handles, back of the backrest or sides of the pushchair will affect the stability of the pushchair and can cause failure of one or more components of the pushchair.

Parts checklist

1

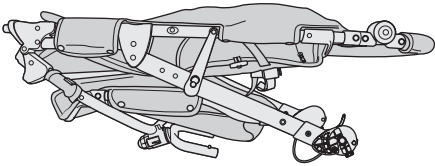

2

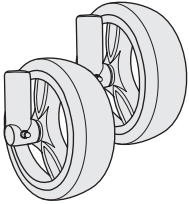

3

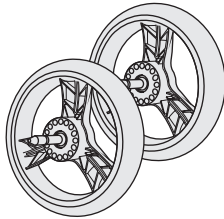

4

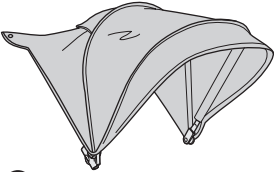

5

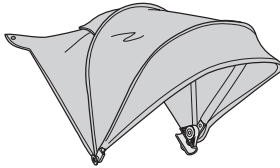

6

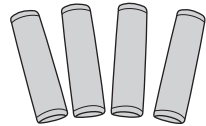

7

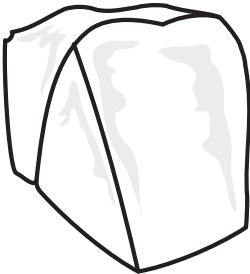

Contained in your carton are:

Nº	Part	Qty
1	Chassis	1
2	Front wheels	2
3	Rear wheels	2
4	Left hand hood	1
5	Right hand hood	1
6	Harness pads*	4
7	Raincover	1

*These are pre-fitted but are removable

Possible combinations using optional extras

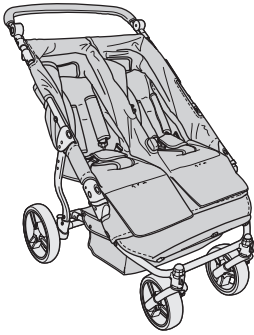

1

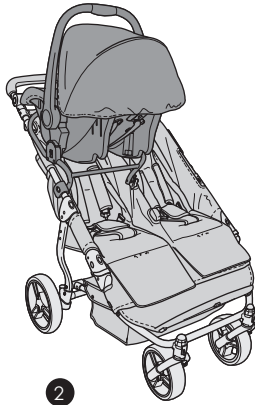

2



3



4



5

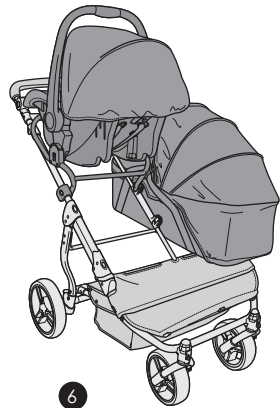

6

There are six possible combinations:

1. Two pushchair seats (no extras).
2. Car Seat on left (requires upper-left-hand car seat adapter).
3. Car seat on both sides (requires upper-left-hand and lower-right-hand adapters)
4. Carrycot on left (requires the left-hand or "main" carrycot)
5. Carrycot on both sides (requires the left-hand or "main" carrycot and right-hand carrycot)
6. Car seat on left + Carrycot on right (requires upper-left-hand adapter and right-hand carrycot)

NOTE! The left and right-hand sides are based on being stood in front of the pushchair.

The left-hand side may also be referred to as the "main" side.

If purchasing any optional extras, then we advise you speak to your retailer or contact our helpline on 0161 335 2508 to ensure you purchase the correct items for your specific situation.

Assembling the pushchair for the first time

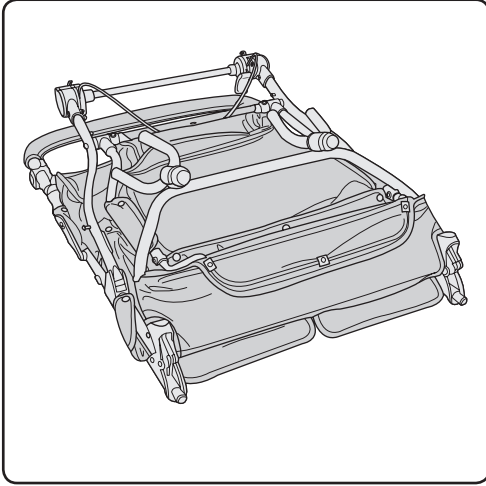

1. Place the pushchair on the floor "face-down" as shown.

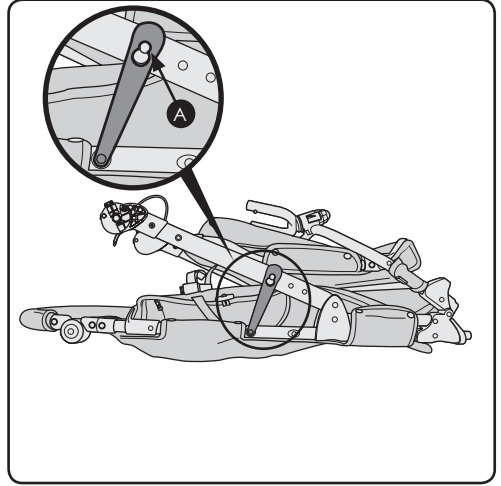

2. Release the folding lock by lifting the lock off the peg (A).

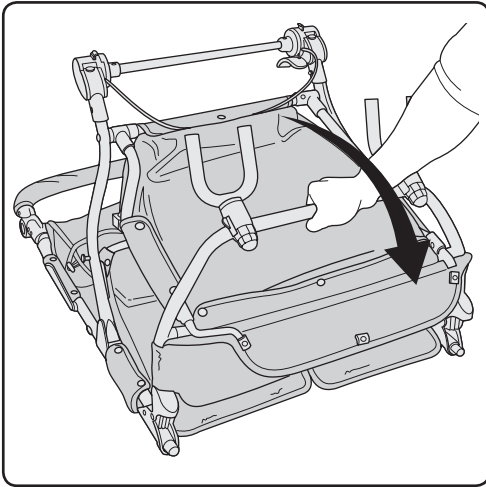

3. Hold the bar at the front of the pushchair as shown and pull the bar towards you to open the pushchair.

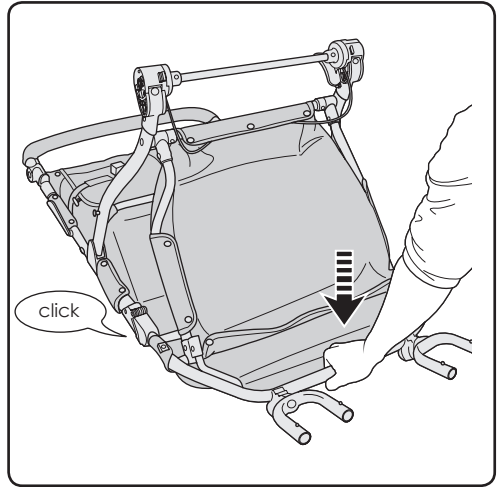

4. Keep pulling until fully open and push the bar downwards until the chassis clicks into the locked open position.

Assembling the pushchair for the first time (continued)

5. Attaching the rear wheels: Push the spindle (C) on each of the rear wheels' into the holes (D) on the outside of the rear axle.

Pull each rear wheel to ensure it is properly attached.

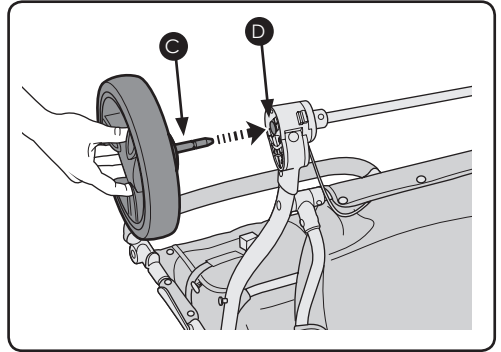

6. Attaching the front wheels: Line up the front wheels so that the holes (A) line up with the spring pins (B) and push the wheels onto the chassis.

Pull each front wheel to ensure it is properly attached.

Once you have attached all the wheels your pushchair can be turned the right way up and is ready to use.

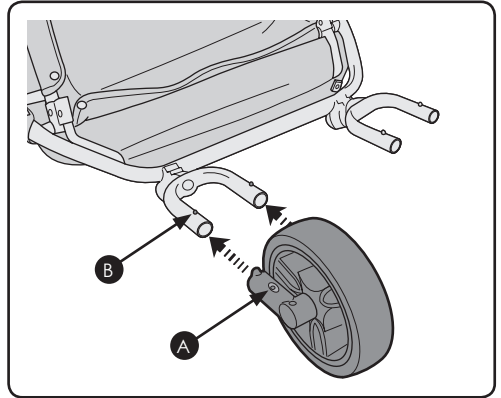

In Use: Opening the pushchair

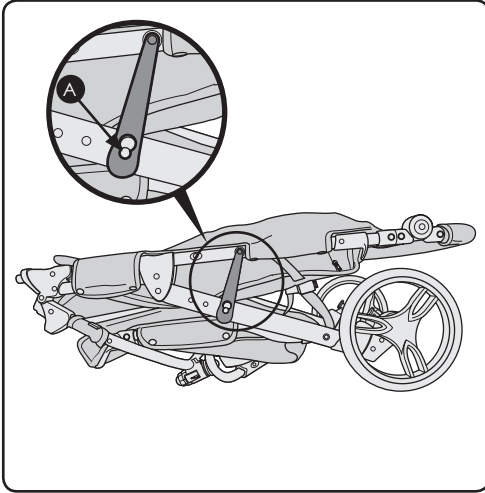

1. Release the folding lock by lifting the lock off the peg (A).

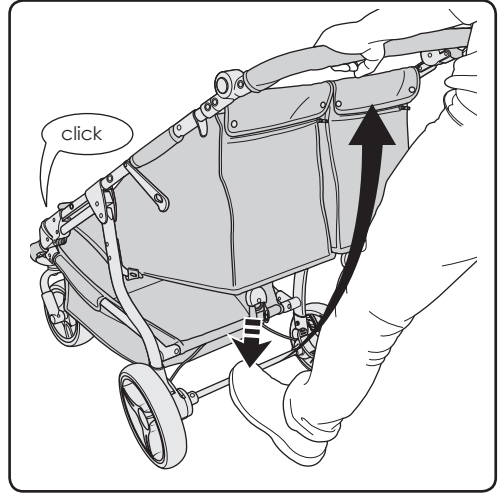

2. Place your foot on the rear axle and raise the handle upwards until the chassis clicks into the locked open position.

In Use: Adjusting the calf rests

1. Push in the button (A) on left-hand side of the chassis and pull the left-hand calf rest (B) down to the desired position. To adjust the right-hand calf rest (C) push in button (D).

To raise the calf rests simply lift the calf rest up.

WARNING! DO NOT ALLOW YOUR CHILD TO CLIMB OR STAND ON THE CALF REST.

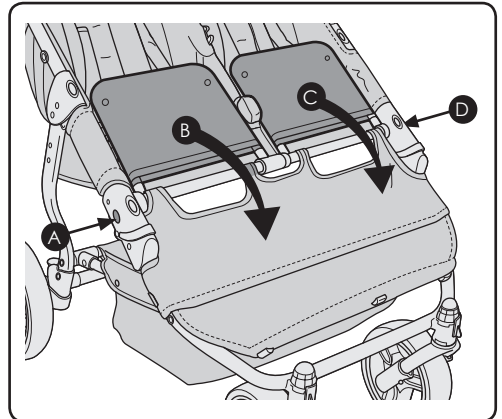

In Use: Adjusting the handle

1. Push in the buttons (A) on each side of the pushchair handle and tilt the handle upwards or downwards as desired.

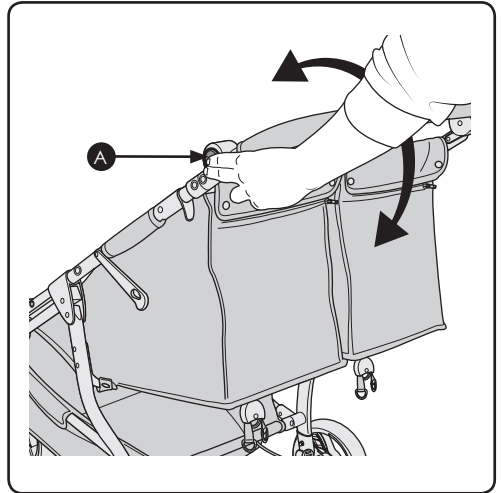

In Use: The brake

WARNING: The brake MUST always be ON when making adjustments, e.g. taking the child out, putting the child in or letting go of the handlebar.

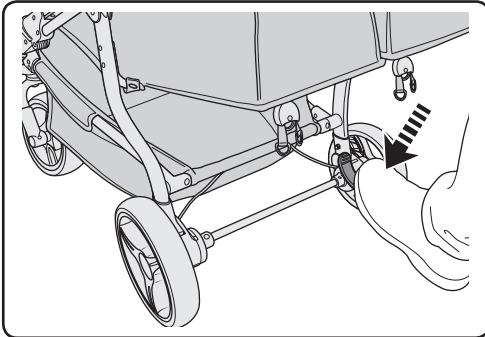

1. Press down on the brake lever with your foot to apply the brake. Push the pushchair backwards and forward to make sure the brake is engaged before letting go of the handles.

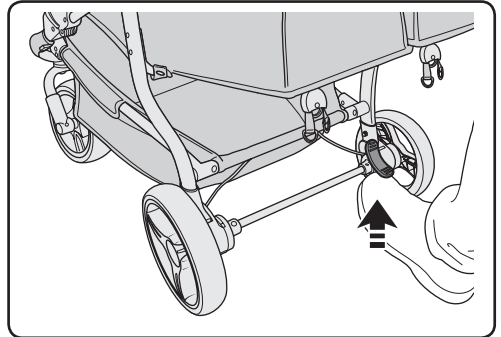

2. Pull the brake lever up with your foot to release the brake.

WARNING! Make sure you are holding the handles before releasing the brake.

In Use: The swivel/lock function

The wheels have three locking positions: 1. Full swivel, 2. Partial swivel, 3. Full lock.
WARNING: Always use the full lock when using the pushchair on rough surfaces.

- 1. Full Swivel:** Turn the swivel lock (A) all the way to the right.
- 2. Partial Swivel:** Turn the swivel lock to the middle position. This will allow the wheels to swivel from side to side slightly but will not allow them to fully swivel when pushing the pushchair.
- 3. Full Lock:** Turn the swivel lock all the way to the left. This will prevent any swivel and keep the wheels in a straight line when pushing the pushchair.

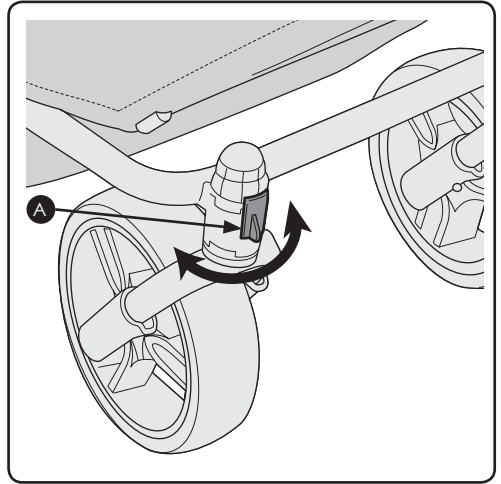

In Use: The harness

WARNING: Ensure each harness is correctly fitted at all times.
Adjust the sliders on the waist and shoulder straps so that the harness fits snugly.

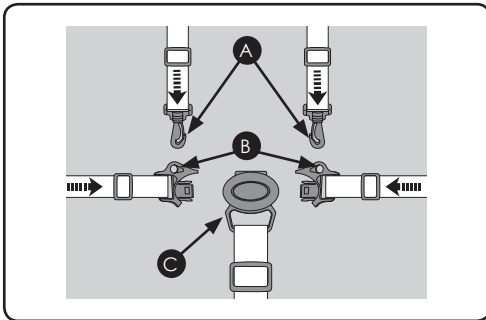

- 1. To lock:** Clip the shoulder harness strap clips (A) onto the loop of the waist strap connectors (B).

Push the waist strap connectors (B) into the buckle (C) until they CLICK into place.

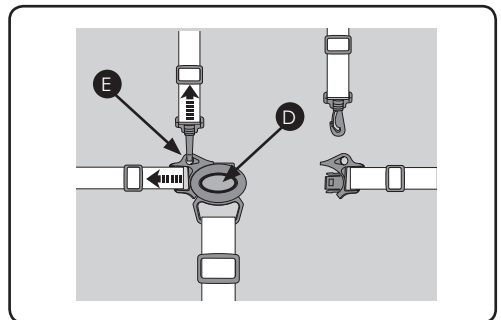

- 2. To release:** Press the button (D) in the centre of the buckle. The shoulder straps can be unclipped from the waist straps if necessary (E).

In Use: Adjusting the shoulder harness position

The shoulder straps and waist straps can be repositioned to suit the size of your child. Use the shoulder straps in one of the three positions that is closest to your child's shoulder height and use the waist straps in one of the two positions that best fits your child's waist.

WARNING! Ensure harness is correctly fitted at all times.

1. Unclip the shoulder straps from the waist strap, remove the shoulder pads and position the shoulder straps through either fabric loops (1) or slots (2) or (3) on the seat-back at the desired height (see step 1a below for more details)

Once at the desired height place the shoulder pads back on to the straps and clip the shoulder harness clips back onto the waist strap.

Adjust the waist strap by releasing the buckle and unclipping the shoulder straps. Position the waist straps through either fabric loops (5) or slots (4).

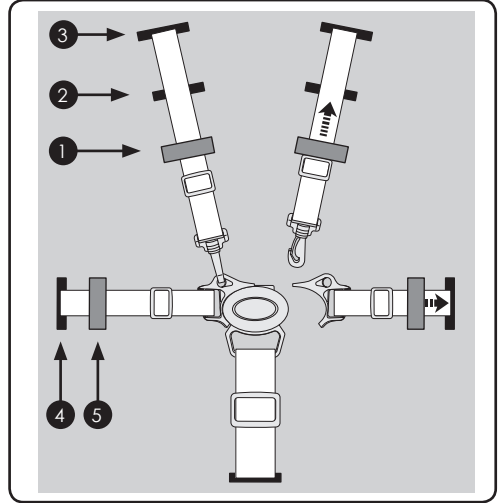

IMPORTANT! Check all straps are fitted correctly and securely, by pulling the straps up sharply.

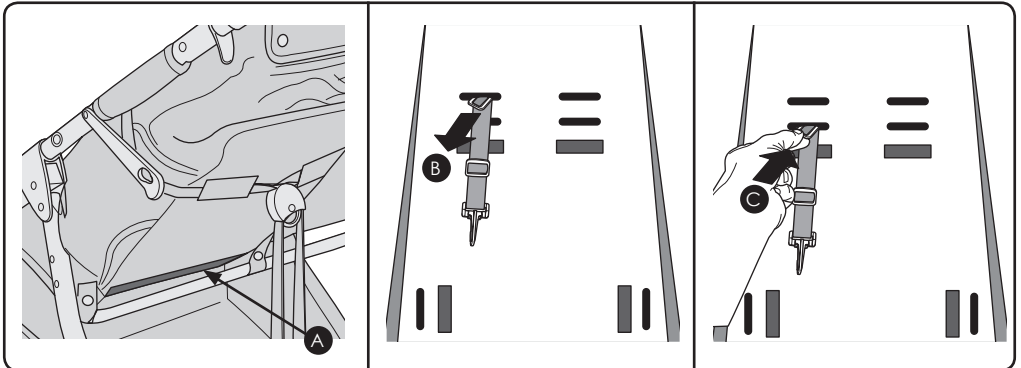

1a. Release the Velcro® tab (A) on the back of the stroller seat to access inside the seat fabric. Insert a hand into the seat fabric and feel for the harness strap retainers. Pass the harness strap retainers through their current slot to the front of the seat (B) and then re-insert the harness strap retainer at the desired height (C)

In Use: Adjusting the backrest

ATTENTION: Ensure the brakes are engaged before adjusting the seats.

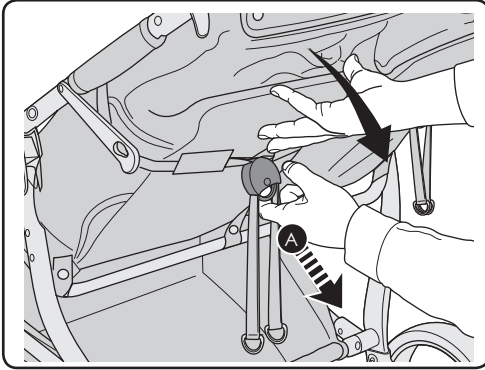

1. **To recline:** Whilst keeping the backrest supported with one hand, pull recline mechanism (A) downwards and carefully lower the backrest. **WARNING!** Do not pull the release mechanism without supporting the backrest.

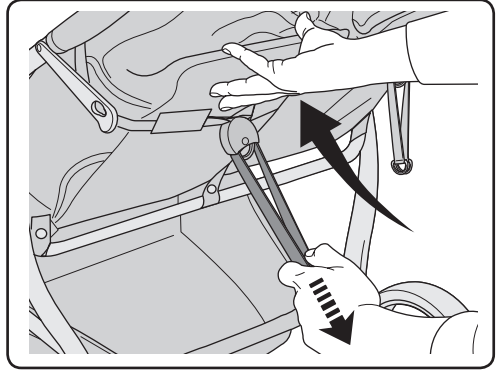

2. **To raise:** First, raise the backrest with one hand and then pull the strap tight with your other free hand. **Note:** Do not try to do both actions at once.

In Use: Attaching/Removing the hood

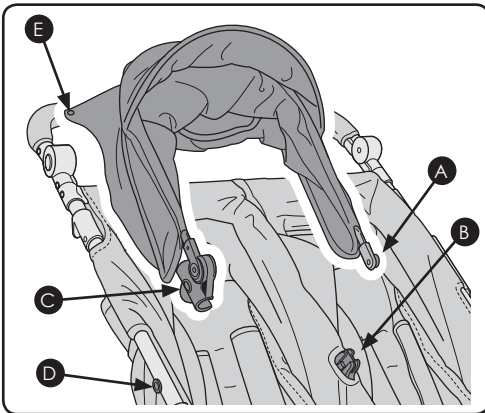

1. Push the round hood connector (A) into the slot on mounting point (B) and connect the hood-clip (C) over the stud at point (D). Finally secure the hood to the back of the seat using the press studs (E) and secure Velcro® tab on the hood to Velcro® tab on outer frame.

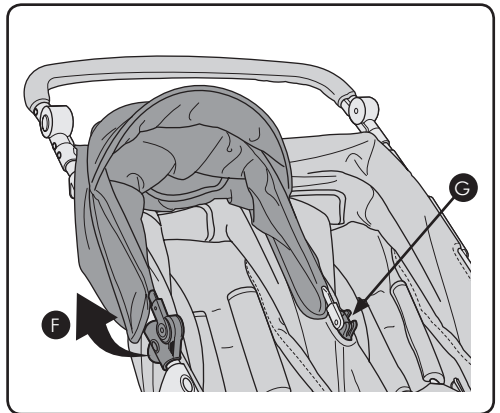

2. To remove the hood; unfasten the press studs on the back of the hood, unclip the hood-clip (F) and pull the round hood connector from the mounting point (G).

In Use: Attaching the raincover

1. Fully open your raincover. With the hoods on the pushchair open, place the raincover over the pushchair hoods lining up the seams and secure all fastenings.

Pull the edges of the raincover over the front of the pushchair and fasten the Velcro® tabs around the front wheel housing.

WARNING: The raincover is for outdoor use only. The cover must be removed or folded back if the child remains in the pushchair indoors, otherwise the child may overheat. Fold back or remove the cover in warm or sunny weather.



In Use: Removing the seat fabrics

If you do not intend to use one or both of the pushchair seats for an extended period of time (i.e. you intend to attach a carrycot) then it is possible to remove the pushchair seat fabrics for storage.

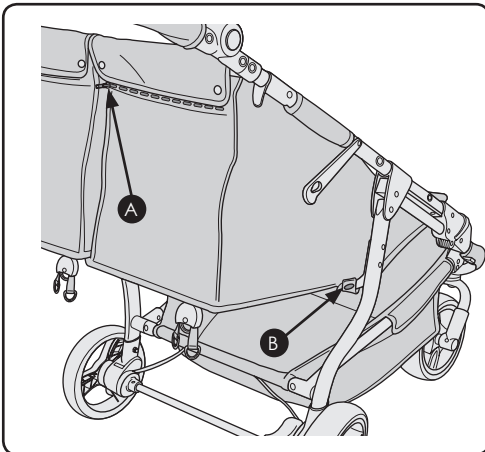

1. Ensure the stroller brake is on and that the stroller cannot move. Release the two press studs at the back of the seat (A) and undo the zip (B).

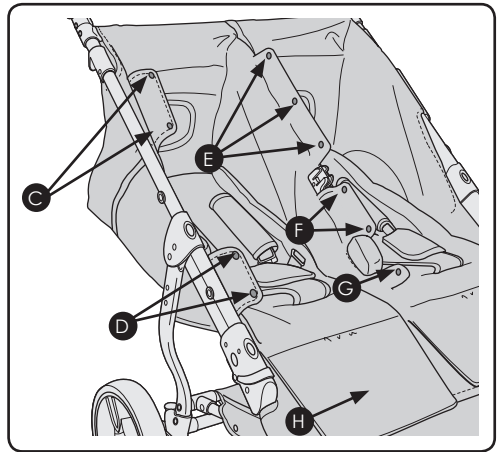

2. Release all the press studs (C, D, E, F, G). Raise the calf rest (H) and unfasten the Velcro® tab on the underside. You can now remove the seat fabric from the chassis.

Repeat steps 1 & 2 on the remaining seat if you wish to remove both seat fabrics.

In Use: Folding the pushchair

WARNING! Fold the hood back before attempting to fold the pushchair.
Failure to do so may damage the hood.

1. Turn both swivel locks (A) to the left to allow full swivel.

IMPORTANT: Failure to follow this step will prevent the pushchair from folding properly.

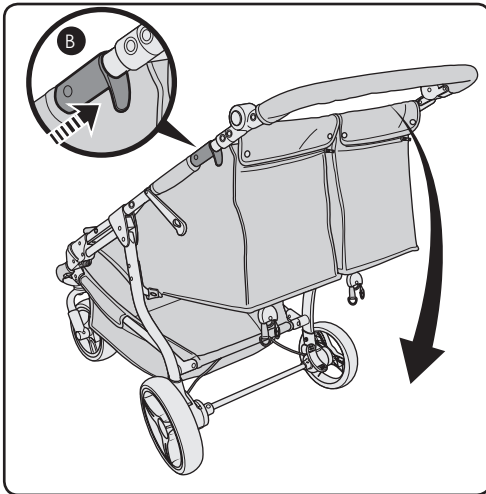
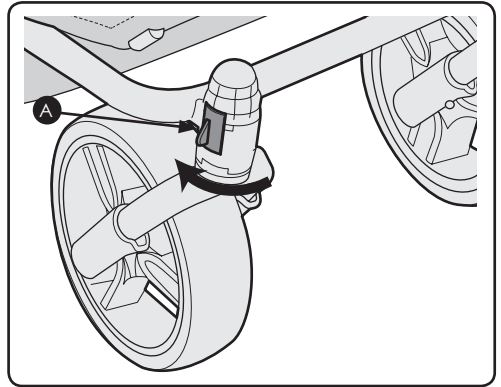

2. Standing behind the pushchair, pull up both release catches (B) and fold the pushchair downwards.

Do not force it down. If it will not fold down easily, check for obstructions (e.g. footmuff, raincover, toys, items in the basket etc) and repeat the previous step if necessary.

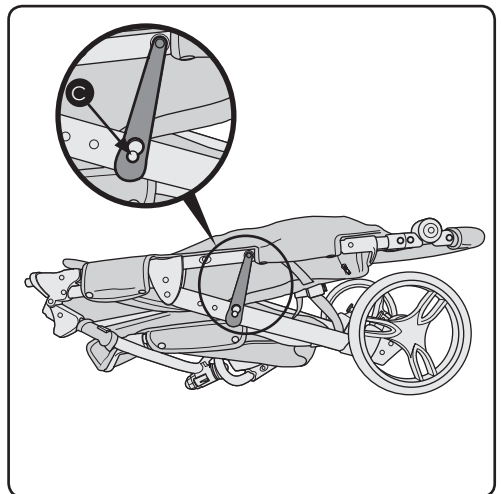

3. Check that the front wheels have folded away under the pushchair and that the folding lock reaches the peg (C).

If the front wheels are obstructing the fold check that they can swivel and turn them so as to allow the pushchair to fold.

After use/storage

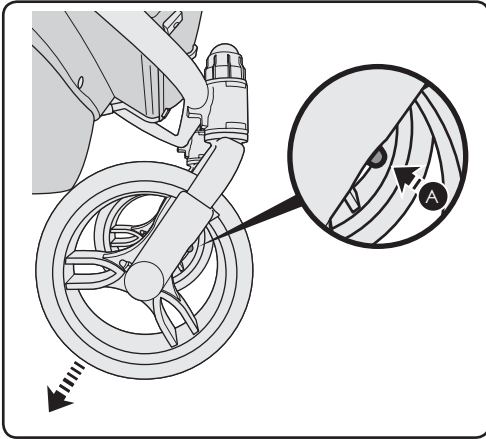

1. **To remove the front wheels:** Push in the two spring pins on the front wheel and pull the wheel off from the chassis.

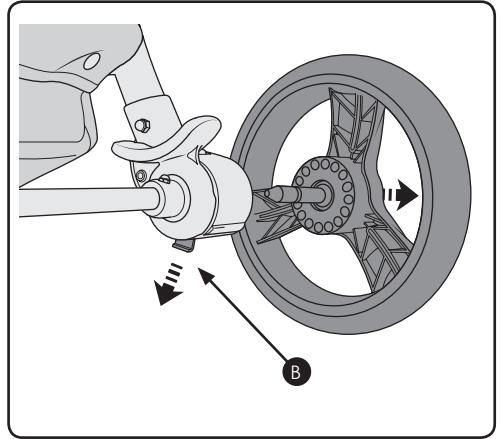

2. **To remove the rear wheels:** Pull the quick release mechanism (B) and pull the wheel out from the rear axle.



If you have any questions or concerns regarding this product,
do not hesitate to contact our expert team online
via online4baby.com/contact-us

Feeling social?  
online4baby.com

Imported by Online4baby Ltd,
Meadowbank, Tweedale Way, Oldham, OL9 8EH