

# Grace Duo Twin Dolls Stroller Pushchair and 2 Car Seats

Instruction manual

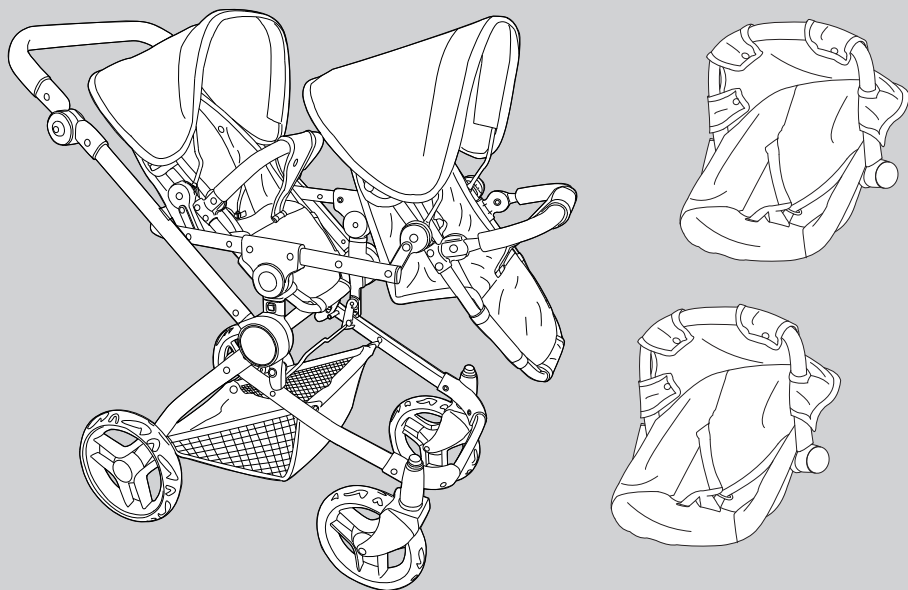

**IMPORTANT - RETAIN FOR FUTURE  
REFERENCE, READ CAREFULLY.**

**Warning:** A child's safety is your responsibility.

This product is tested and approved to  
EN 71 – 1, 2 & 3

# 1 .Welcome

Thank you for purchasing the Puggle Grace Duo Twin Dolls Stroller Pushchair and 2 car seats. Please read the instructions and warnings carefully before use to ensure safe and satisfactory operation of your Puggle Grace Duo Twin Dolls Stroller Pushchair and 2 car seats.

If you have a query with this product or require replacement parts, please contact Online4baby online at [online4baby.com/contact-us](https://www.online4baby.com/contact-us).

## 2. Safety instructions

**IMPORTANT! PLEASE READ THE FOLLOWING INSTRUCTIONS CAREFULLY BEFORE INSTALLING THE PRODUCT.**

- **WARNING!** Keep for future reference. The child may be hurt if you do not follow these instructions.
- **WARNING!** Choking hazard due to small parts.
- **WARNING!** This stroller is not suitable for children under 36 months.
- **WARNING!** This product is a toy and is not suitable for carrying babies, children or pets.
- **WARNING!** Assembly should be carried out by an adult to prevent the item collapsing during use.
- **WARNING!** Please remove all packaging before giving this item to your children.
- **WARNING!** Adults should check the product regularly to prevent collapsing during play.

### 3. Parts List

A

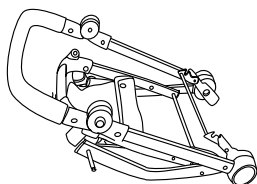

B

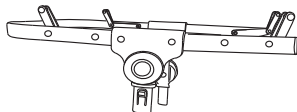

C

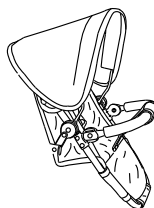

D



E



F

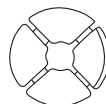

G



H



I

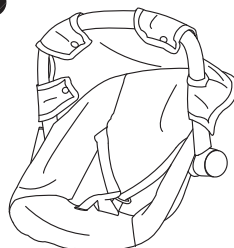

#### Contained in your carton are:

Nº	Part	Qty
A	Chassis	1
B	Seat Unit Frame	1
C	Seat Unit	2
D	Front wheels	2
E	Rear wheels	2
F	Plastic wheel clips	4
G	Front wheel cap	2
H	Rear wheel cap	2
I	Car seat	2

## 4. Assembly

### 4.1. STROLLER ASSEMBLY

Lift the handle to open and unfold the stroller.

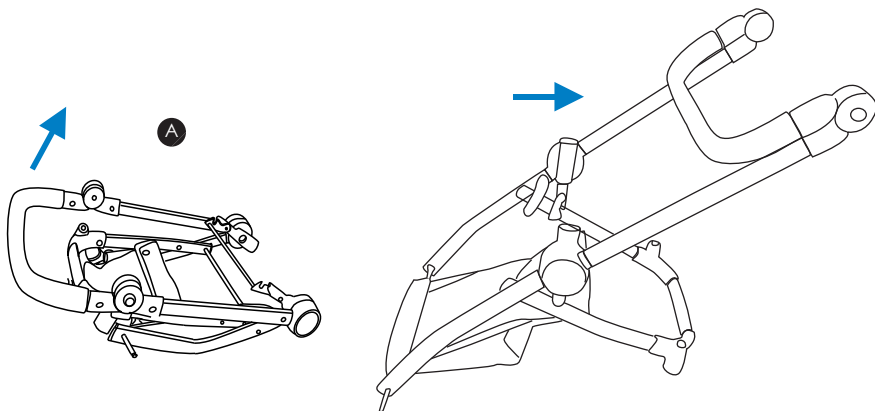

### 4.2. FRONT WHEEL ASSEMBLY

Insert each front wheel (D) pin into the centre of the socket and secure with a plastic wheel clip (F) and front wheel cap (G). Repeat for the other side.

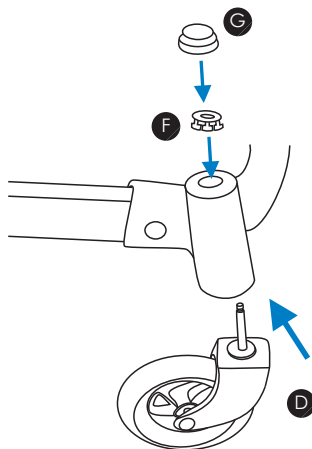

## 4. Assembly

### 4.3. REAR WHEEL ASSEMBLY

Push the rear wheel (E) onto the axle pin.  
Secure the wheel in place using a plastic wheel clip (F).  
Finally attach the rear wheel cap (H).  
Repeat for the other side.

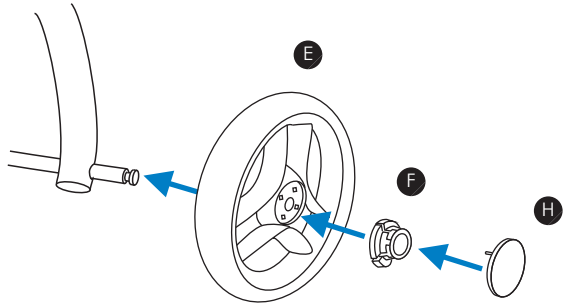

### 4.4. SEAT UNIT FRAME ASSEMBLY

Attach the seat unit frame (B) to the chassis (A). Line up the seat unit frame connectors to the chassis housing and press down until you hear a "click".

**To note**, the open end of the seat unit frame should be at the front.

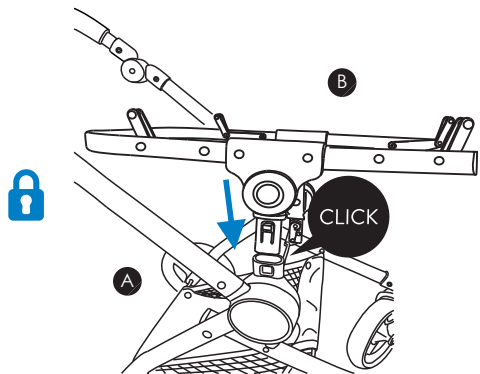

## 4. Assembly

### 4.5. SEAT UNIT ASSEMBLY

To attach the seat unit (C) line up the seat unit connectors with the seat unit frame (B) housing and press downwards to slot together.

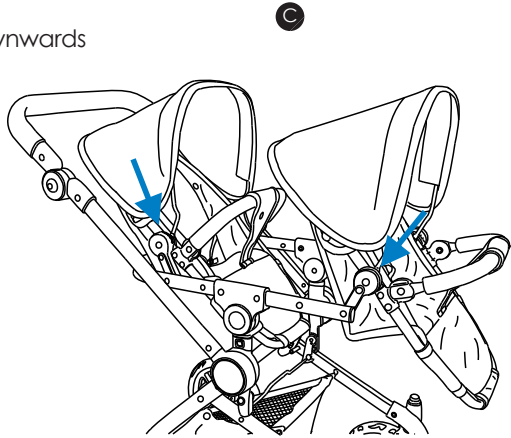

The second seat unit is reversible. Lift the seat unit upwards to slide off the seat unit housing and turn the seat. Then reattach the seat unit connectors to the seat unit frame housing.

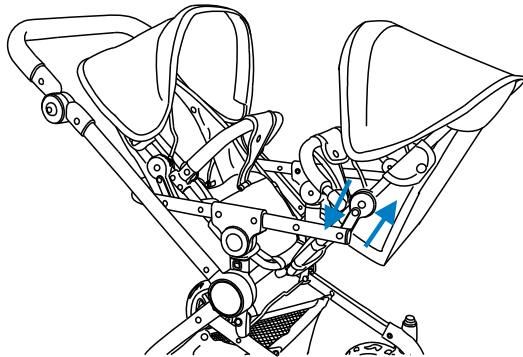

## 5. Handlebar adjustment

### 5.1. HANDLEBAR ADJUSTMENT

Adjust the height of the handle by pressing the handlebar height adjustment buttons located on either sides of the handlebar. At the same time adjust the handle up or down. Release buttons at your desired position. The handlebar will "click" into place.

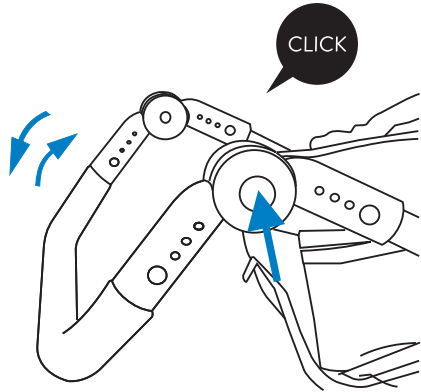

### 5.2. HANDLEBAR DIRECTION ADJUSTMENT

Push the handlebar direction adjustment buttons. At the same time adjust the direction of the handlebar. The handlebar frame will "click" into place.

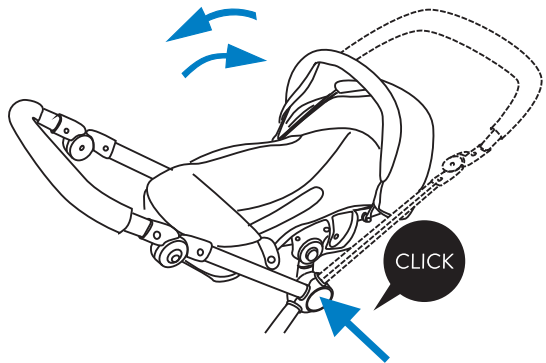

## 6. Folding

### 6.1. REMOVE SEAT UNITS

Remove both seat units from the seat unit frame.

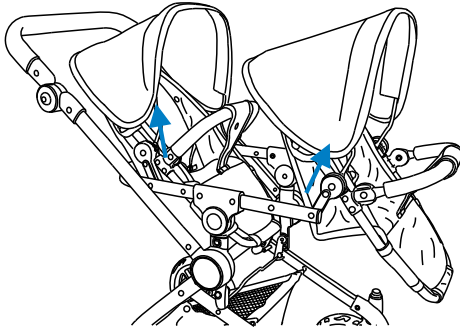

### 6.2. REMOVE SEAT UNIT FRAME

Remove the seat unit frame from the chassis. Press the seat unit frame release buttons on either side of the frame and lift off.

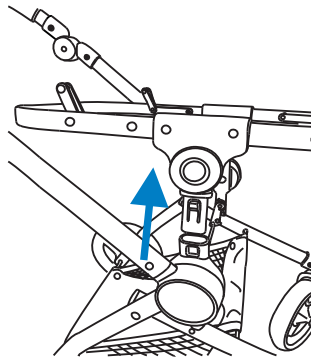



## 6. Folding

### 6.3. UNHOOK FRAME LATCHES

Unhook the locking latch (1), then push the second latch (2) to release the frame, the front section of frame will start to fold.

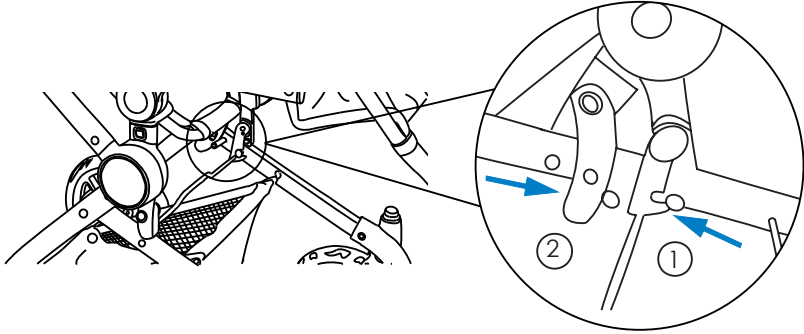

### 6.4. FOLDING CHASSIS

Press the directional adjustment buttons at either side of the frame and fold the handlebar as the front wheels also fold inwards.

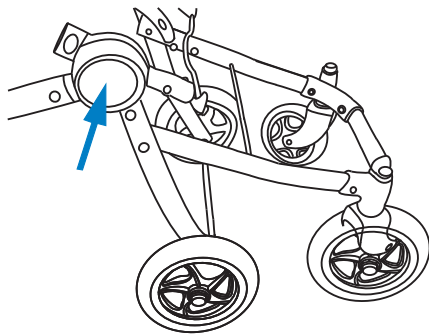

## 7. Care and Maintenance

### 7.1. CLEANING

- Spot or sponge clean fabrics with mild detergent. Use mild soap or upholstery shampoo. NEVER use bleach. Dry in shade thoroughly before reuse and avoid direct heat and sunlight. Do not iron. Do not dry clean.
- Wipe clean plastics and metals with a damp cloth.
- Never clean any part of the product with abrasive, ammonia based, bleach based or spirit type cleaners.
- Ensure the product is fully dry before use or storage.
- Always ensure the product is stored in a dry place to prevent mold or mildew developing.

### 7.2. MAINTENANCE

- The product requires regular maintenance to ensure correct and safe performance.
- Regularly inspect the joints and fixings to ensure they are clean, operating correctly and in full working order.
- Do not use this product if any part is broken, torn or missing and use only spares provided by the manufacturer.
- If parts become stiff or difficult to operate, ensure dirt is not the cause, then try a light application of a silicon lubricant, ensuring it penetrates between the components. Regular lubrication of moving parts will extend the life of your product and make opening and folding easier.
- After exposure to damp conditions, dry off with a soft cloth and leave fully open in a warm environment. Storing damp will encourage mildew to form.
- Store in a dry place.
- Do not leave in sunlight for prolonged periods as some fabrics may fade.





If you have any questions or concerns regarding this product,  
do not hesitate to contact our expert team online  
via [online4baby.com/contact-us](https://online4baby.com/contact-us)

Feeling social?    
[online4baby.com](https://online4baby.com)

Imported by Online4baby Ltd,  
Meadowbank, Tweedale Way, Oldham, OL9 8EH